

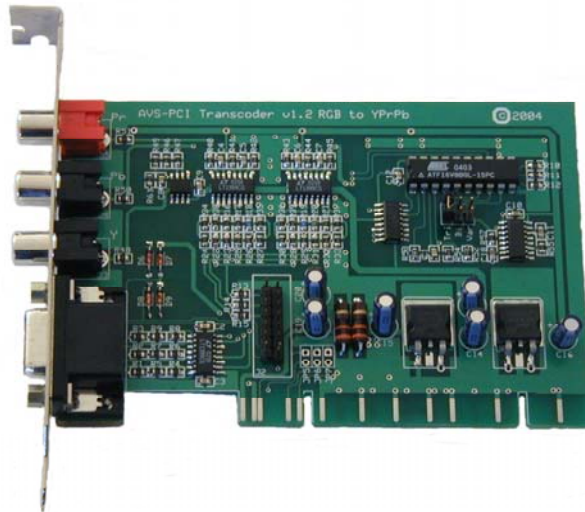

TCP2200 Transcoder Users Manual



Introduction

The **Crescendo-Systems TCP2200** transcoder is a highly flexible device that allows you to connect your computer to your HDTV monitor. The **TCP2200** has been tested for 480p, 540p, 720p and 1080i, but will support other resolutions. In contrast to most other transcoders on the market, the **TCP2200** supports three modes of synchronization handling and is therefore optimally suited to drive a variety of display devices.

Also unique is the fact that the **TCP2200** supports both color conversions for 480p and 720p/1080i in order to provide optimum color fidelity. Although the required conversions are nearly identical, the difference cannot be ignored when optimum quality is pursued.

In order to use the **TCP2200** on a computer the timing has to be set such that the display device will accept it. A freeware program called PowerStrip™ is available from www.entechtaiwan.com/ps.htm that can assist to achieve this. There are various guides available that explain PowerStrip™ in detail, an excellent one is on the [AVSForum](#) and a second one is available at [KeohiHDTV](#).

Warning! Setting incorrect scan-frequencies can seriously damage your TV. Crescendo-Systems takes no responsibility implied or otherwise and Crescendo-Systems' total liability to any customer for any and all claims relating to the use of the **TCP2200** shall not exceed the total amount paid by such user to Crescendo-Systems for obtaining this product.

Specifications

The **TCP2200** offer the user total flexibility and has the following specifications and features:

- Highly flexible VGA (RGBHV) to Component (YPrPb) transcoder
- Optional buffered VGA loop-through
- Three timing modes:
 1. Fixed width tri-level sync
 2. Fixed width bi-level sync
 3. Transparent timing to support most video formats, interlaced or progressive
- User selectable color conversion
- Drives cables up to 50 feet (16m)
- High bandwidth (>130MHz) signal processing
- Input on a female VGA connector
- Optional loop-through output on a female VGA connector. Gain=1 when driving 75 Ohm
- Component (YPrPb) output on three RCA connectors. Vout=1Vp-p when driving 75 Ohm

Included in this package are one **TCP2200** PCI card. The manual with warrantee statement will be sent by email and optionally can be directly downloaded from the Crescendo-Systems website.

Setup

The **TCP2200** gives the user the possibility to choose the type of sync signal that best suits the display device used. The user has three choices:

1. Fixed width tri-level sync (jumper on **Tri**)
2. Fixed width bi-level sync (jumper on **Bi**)
3. Variable bi-level sync (jumper on **Var**)

According to the HDTV standard, all resolutions higher than 480p require tri-level sync. Although most TV's lock just as well to signals using bi-level sync, the line stability is generally considered to be better using a tri-level sync.

The **TCP2200** can also generate bi-level sync with a fixed width of 1.2 μ s that is independent of the incoming horizontal sync signal. It may be possible that some

standard definition TV's will not be able to lock to this signal as the required width for a 480i signal is larger.

In that case it is recommended to use the variable bi-level sync option in which the source device sets all timing parameters and the **TCP2200** is transparent to all timing. In this mode the **TCP2200** behaves exactly like the **TC2000**.

To select the desired timing mode, a jumper has to be set in the appropriate position on the encircled jumper block as shown in the picture below.

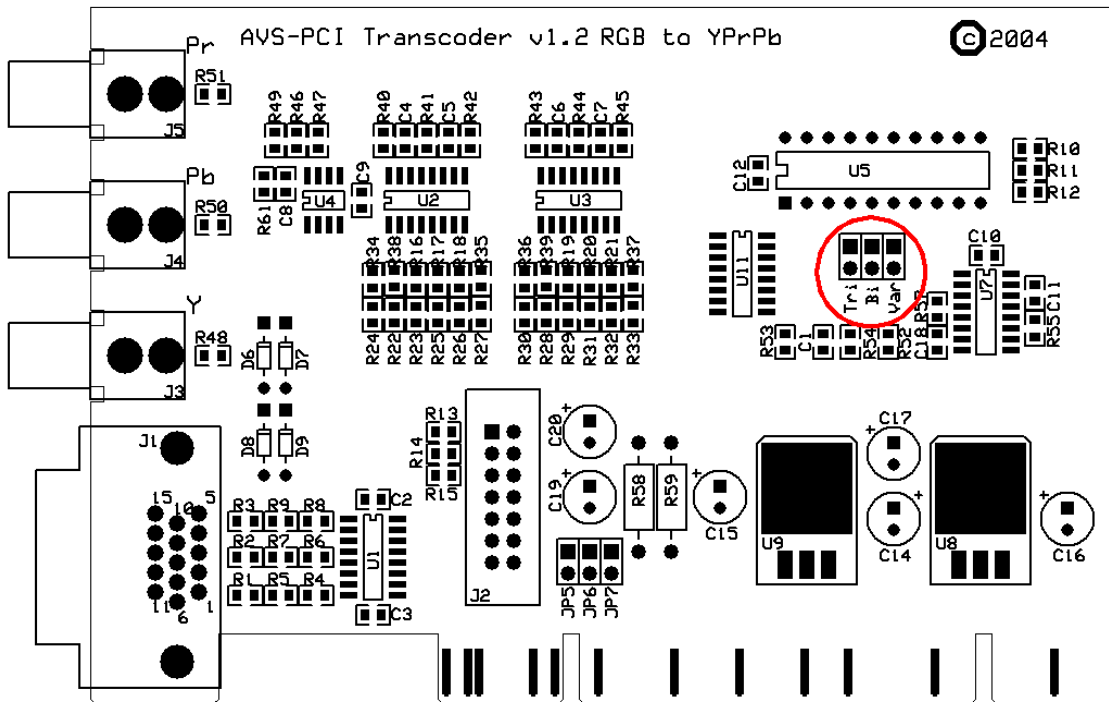

In order to successfully use your **TCP2200** just follow the simple steps outlined below.

1. Make sure that your source device has the ability to correctly set the timing needed by your display. **If this is not the case do not use the TCP2200.**
2. Install the **TCP2200** in a any free PCI slot. The card will only draw power from the PCI slot and there are drivers to install. If the optional pass-through bracket has been purchased as well, two free adjacent PCI slots are needed.
3. Connect your source to the **TCP2200** using a VGA cable with a male HD15 connector.

4. Connect the **TCP2200** to your display using the Component output jacks. Additionally, you can connect a VGA monitor to the optional VGA (loop-through) output.
5. Make sure that the source device has the correct timing setup, if necessary verify this by using a multi-sync monitor connected to the loop-through output. This is an important step and should not be taken lightly. When using PowerStrip™ please familiarize yourself with this program first.
6. Select the desired sync mode by setting the jumper on the timing jumper block. The default setting out of the box is tri-level sync.
7. Select the desired color conversion by choosing the polarity of the sync:
 - a. H-sync and V-sync negative: color conversion for 480p
 - b. H-sync and V-sync positive: color conversion for 540p/720p/1080i
 Be sure to always set the same polarity for H-sync and V-sync, otherwise your display may not correctly lock to the signal and may become damaged.

Technical details and tips

The **TCP2200** implements the following two color conversions.

For 480p:

$$\begin{aligned}
 Y &= 0.2990R + 0.5870G + 0.1140B \\
 P_b &= 0.5643 (B-Y) = -0.1687R - 0.3312G + 0.5B \\
 P_r &= 0.7133 (R-Y) = 0.5R - 0.4187G - 0.0813B
 \end{aligned}$$

For 540p/720p/1080i:

$$\begin{aligned}
 Y &= 0.2126R + 0.7152G + 0.0722B \\
 P_b &= 0.5389 (B-Y) = -0.1146R - 0.3854G + 0.5B \\
 P_r &= 0.6350 (R-Y) = 0.5R - 0.4542G - 0.0458B
 \end{aligned}$$

In tri-level sync mode the **TCP2200** generates a 600ns wide negative sync pulse immediately followed by a 600ns positive sync pulse. The start of a new TV line is defined to occur at the moment of zero crossing.

In fixed width bi-level sync mode, a negative sync pulse of 1.2us wide is generated and as stated before, this may not be wide enough for some standard definition TV's.

In variable timing mode, the **TCP2200** relies on the source device or a program like PowerStrip™ to set the correct horizontal and vertical sync width. A TV expects a H-sync width of around 2μs for 480p and around 1μs for 540p/720p/1080i. If the H-sync width is too long, the picture will look washed out with a white haze on it. A computer monitor on the loop-through will not show this effect because this kind of monitor is highly insensitive to the H-sync width.

If the picture looks washed out, try reducing the width of the H-sync, while keeping the scan frequencies locked, until the picture looks good and a further reduction makes no difference anymore. Do not reduce the H-sync width too much, 0.6 μ s is normally the minimum width before a TV loses lock.

Warranty

Crescendo-Systems designs and builds all products with the highest of care and every product should operate trouble-free for many years when used under normal operating conditions. Therefore, every **TCP2200** carries a 1-year no-hassle replacement warranty. Should a warranty replacement be needed, please contact sales@crescendo-systems.com first.